



Figure 5.4 Photograph of cul-de-sac island as play area.

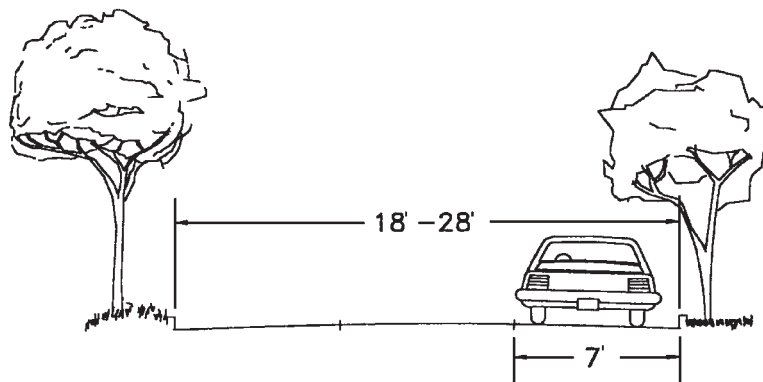

Figure 5.5 Residential street detail, parking on only one side.

Attempts to force unrealistic standards in an environment that requires special consideration inevitably creates as many problems as it solves. Furthermore, trying to fit a square peg in a round hole often increases the costs of development while not improving the living environment and actually losing the site character and some of its natural elements that made the site attractive in the first place.